

Features

- PROFIBUS DP V1 / For 4 segments PA
- Couples PROFIBUS PA devices transparently to PROFIBUS DP
- Optional redundant configuration
- Installation in Zone 2/Class I, Div. 2
- Up to 12 Mbit/s, auto adapting
- For redundant and non-redundant masters
- Supports Flying Redundancy (FR)
- Cyclic/acyclic data exchange

Function

The PROFIBUS Power Hub gateway is a system component of the FieldConnex® PROFIBUS Power Hub (Segment Coupler 3 or SK3) and plugs into the gateway motherboard. The gateway operates with power supply modules connected to the same or a separate motherboard. This system component transparently couples PROFIBUS DP with up to 4 PROFIBUS PA segments.

Communication is transparent between DP and PA. The gateway of the Segment Coupler makes each PA device appear as if it was connected to DP: This relates to addressing, cyclic/acyclic data exchange, and the transfer rate. Segment design is clear and easy to understand without subnetworks. The gateway itself is configuration-free. All in all, these features significantly reduce engineering work.

The gateway provides a PA master for each segment and thus enables short bus cycle times.

In redundant configuration, 2 PROFIBUS gateway modules operate with handshake between each communication. During redundancy transfer, communication is seamless for DP master and field devices, ensuring continued plant operation. Internal status is reported via volt-free contact and via diagnostic telegram on PROFIBUS DP.

Assembly



Connection

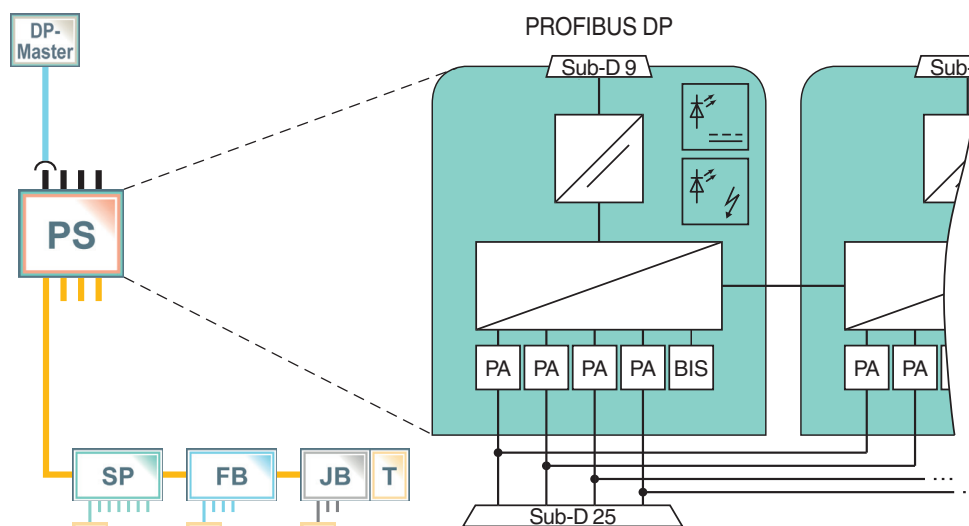

Release date 2019-05-06 13:31 Date of issue 2019-05-06 180563_eng.xml

General specifications		
Design / Mounting		Motherboard based
Supply		
Rated voltage	U_r	19.2 ... 35 V DC
Rated current	I_r	160 ... 90 mA
Power dissipation		3 W
Fieldbus interface		
PROFIBUS DP		
Connection		9-pin Sub-D socket
Protocol		PROFIBUS DP V1
Indicators/operating means		
LED Seg 1...4		red 2 Hz flashing: PA error, red and LED DP/ERR red: MAU error
LED PWR		green: Power on
LED DP/ERR		red 2 Hz flashing: DP error ; red: Hardware error
LED Red.		yellow: redundant operation primary device ; yellow 2 Hz flashing: synchronization or redundancy not available
Galvanic isolation		
CH/PROFIBUS DP		functional insulation acc. to IEC 62103, rated insulation voltage 50 V _{eff}
PROFIBUS DP/Supply		functional insulation acc. to IEC 62103, rated insulation voltage 50 V _{eff}
CH/CH		functional insulation acc. to IEC 62103, rated insulation voltage 50 V _{eff}
All circuits/FE		functional insulation acc. to IEC 62103, rated insulation voltage 50 V _{eff}
Directive conformity		
Electromagnetic compatibility		
Directive 2014/30/EU		EN 61326-1:2013
Low voltage		
Directive 73/23/EEC		EN 50178 (identical to EN 62103)
Standard conformity		
Galvanic isolation		IEC 62103
Electromagnetic compatibility		NE 21:2011
Degree of protection		IEC 60529
Fieldbus standard		IEC 61158-2
Shock resistance		EN 60068-2-27
Vibration resistance		EN 60068-2-6
Ambient conditions		
Ambient temperature		-40 ... 60 °C (-40 ... 140 °F)
Storage temperature		-40 ... 85 °C (-40 ... 185 °F)
Relative humidity		< 95 % non-condensing
Shock resistance		15 g 11 ms
Vibration resistance		1 g , 10 ... 150 Hz
Pollution degree		max. 2, according to IEC 60664
Corrosion resistance		acc. to ISA-S71.04-1985, severity level G3
Mechanical specifications		
Housing material		Polycarbonate
Housing width		40 mm
Housing height		106 mm
Housing depth		128 mm
Degree of protection		IP20
Mass		250 g
Mounting		motherboard mounting , mounting in any orientation
Data for application in connection with hazardous areas		
Certificate		TÜV 04 ATEX 2500 X
Marking		⊕ II 3 G Ex nA IIC T4 Gc
Directive conformity		EN 60079-0:2012 , EN 60079-11:2012 , EN 60079-15:2010
International approvals		
FM approval		
FM certificate		FM 19 US 0015 X and FM 19 CA 0011 X
FM marking		AEx/Ex ec IIC T4
IECEX approval		
IECEX certificate		IECEX TUN 13.0038X
IECEX marking		Ex nA IIC T4 Gc
Certificates and approvals		
Marine approval		DNV A-14038
General information		

Release date 2019-05-06 13:31 Date of issue 2019-05-06 180563_eng.xml

Supplementary information

Observe the certificates, declarations of conformity, instruction manuals, and manuals where applicable. For information see

Dimensions

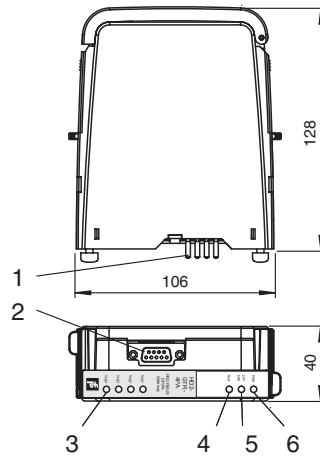

Description:

- 1 Plug connections to motherboard
- 2 PROFIBUS DP interface
- 3 LED Seg 1 ... Seg 4:
- Red flashing with 2 Hz: PA error, double slave address
- 4 LED Redundancy:
- Yellow constant: Redundancy operation primary device
- Yellow flashing: Synchronization
- 5 LED DP/Error:
- Red flashing with 2 Hz: DP error
- Red constant: Hardware error
- 6 LED Power:
- Green: Power on